



CANSOLIDATOR®

Assembly Instructions

ADJUSTING FOR CAN WIDTH

1. Before attaching the next track, hold it slightly above the bracket with your first can in between both tracks. Then, using the numbers on the bracket, determine the appropriate width between tracks to accommodate the can (leave about 1/8" on each side of the can so that it doesn't bind in the track). Now press the track downward into the bracket. Continue this process with each track to achieve the desired width for all tracks.

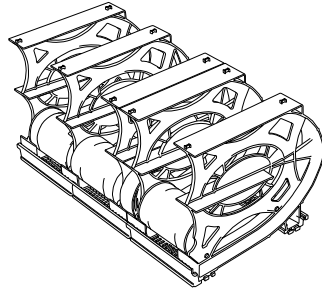

2. Finally, using the numbers on the top and bottom side of the bracket, attach the remaining 2 bracket sets to the top of the CanSolidator in the corresponding bracket holes. Attach the front bracket right side up (same as lower brackets) and the rear bracket upside down. When this is complete, the CanSolidator is ready to be filled with cans.

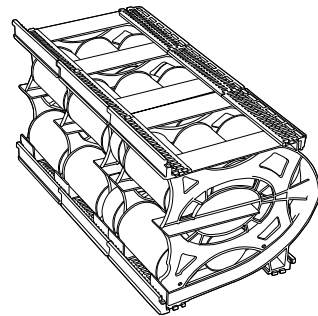

Note: To conserve space above your CanSolidator, you may turn the top front bracket upside down if you are not storing larger fruit/pie filling cans and you are not building additional CanSolidator levels on top.

CONFIGURATION

Stack'em—The CanSolidator is designed to be stackable. Simply insert more tracks into the top brackets of your existing CanSolidator and up you go!

Note: Do not stack your CanSolidator more than 4 levels high.



Expand'em—You can easily expand your CanSolidator as wide as you'd like. Just connect more brackets end to end, insert tracks, and away you go!



NEED MORE PARTS?

Contact us at (877) 743-5373 or www.thrivelife.com



ASSEMBLY INSTRUCTIONS

CANSOLIDATOR®

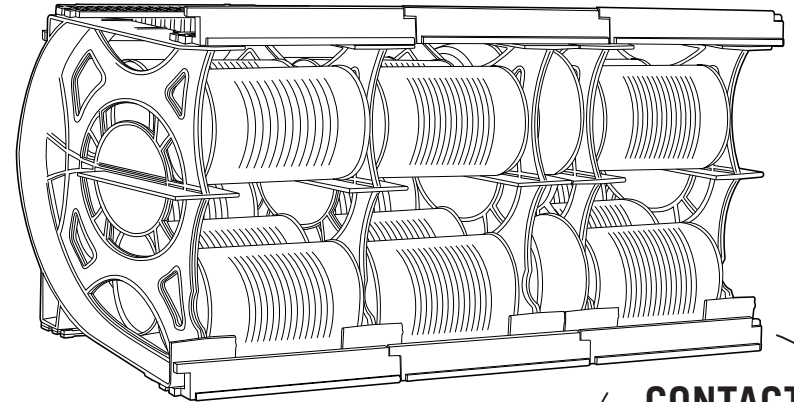

CONTACT US FIRST!

If you have damaged or missing parts, please contact us by phone or email.

Thrive Life™ | 691 South Auto Mall Drive

American Fork, UT 84003 | 877-743-5373 | support@thrivelife.com



CANSOLIDATOR®

Assembly Instructions

COMPONENTS

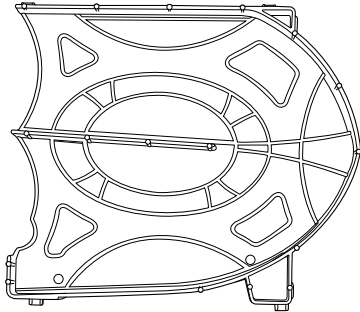

Tracks

- CanSolidator Cupboard (5)
- CanSolidator Pantry (5)
- CanSolidator Pantry Plus (7)

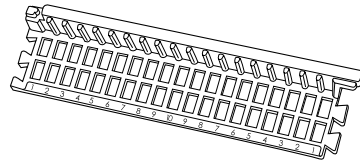

Brackets

- CanSolidator Cupboard (12)
- CanSolidator Pantry (8)
- CanSolidator Pantry Plus (12)

BRACKET ASSEMBLY

To assemble your CanSolidator®, start by connecting brackets into 4 sets of brackets of equal length. To do this, line up 2 brackets end to end, holding the end of one with teeth slightly above the end of one with grooves, and press down on the top bracket so that its teeth insert into the grooves on the lower bracket.

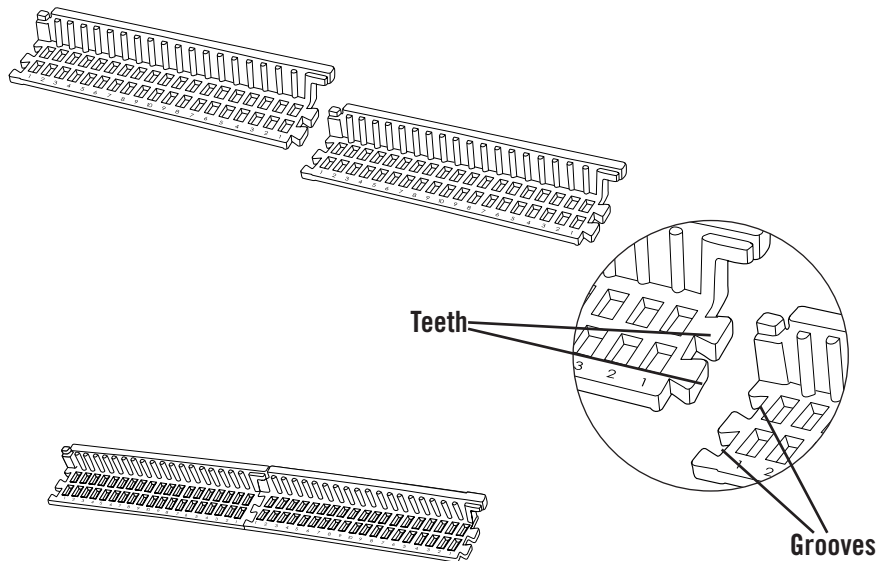

CANSOLIDATOR®

Assembly Instructions

TRACK ASSEMBLY

1. Align 2 bracket sets across from each other with the numbered edges facing inward.

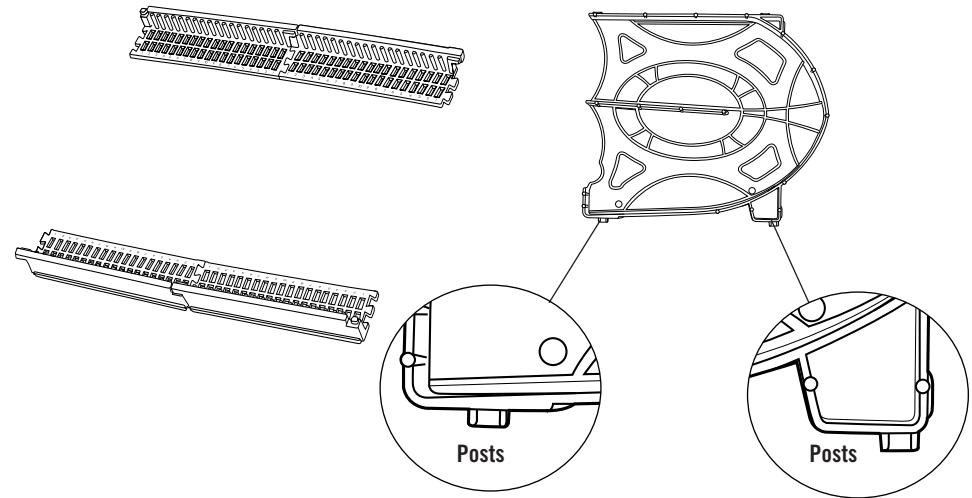

2. Press the first track downward so the posts fit firmly into hole #1 on the brackets.

